



MAX48N-12A10AC0500

MAX48

LINEAR ENCODERS

SICK
Sensor Intelligence.



Illustration may differ

Ordering information

Type	Part no.
MAX48N-12A10AC0500	1219926

Accessories not included with delivery, please order separately.

Other models and accessories → www.sick.com/MAX48



Detailed technical data

Safety-related parameters

MTTFd: mean time to dangerous failure	69 years (EN ISO 13849-1) ^{1) 2)}
--	--

¹⁾ This product is a standard product and does not constitute a safety component as defined in the Machinery Directive. Calculation based on nominal load of components, average ambient temperature of electronic 60 °C, frequency of use 8760 h/a.

²⁾ Every second failure of an electronic component is regarded as a dangerous failure.

Performance

Measured values	Positioning
Measuring range	
Position (F.S.)	0 mm ... 500 mm ¹⁾
Unusable range	
Null zone	30 mm
Damping zone	30 mm
Switch-on time	< 250 ms
Measuring frequency (internal)	2 ms
Transmission rate (cycle time)	Constant analog output signal
Setpoint tolerance	
Zero point and F.S.	≤ ± 1 mm
Resolution	Typ. 0.1 mm (noise-free)
Hysteresis	± 0,1 mm
Repeatability	Typically ± 0.2 mm
Linearity (in the operational status)	Typ. ± 0.25 mm (measuring range 50 to 500 mm) Typ. ± 0.04% F.S. (measuring range from 500 to 2,500 mm)
Temperature drift	
Self-heating of the electronics (warm-up phase)	Typ. ≤ ± 0.25 mm (2 min)
Operational status (hydraulic oil at operating temperature)	≤ ± 0.005 % x F.S. x ΔT (ΔT 40 °C) ²⁾

¹⁾ F.S. = Full Scale (Measuring range).

²⁾ 40 °C increase in oil temperature during operation.

Interfaces

Communication interface	Analog
Communication Interface detail	Current

Current output	4 mA ... 20 mA
-----------------------	----------------

Electrical data

Connection type	Male connector, M12, 4-pin
PIN assignment	1=V DC; 2=n.c.; 3=GND; 4=SIG
Voltage supply	24 V DC (8 ... 36 V DC)
Residual ripple	< 1% S-S
Power consumption	≤ 1.25 W
Current consumption	≤ 50 mA
Load resistance	
	Current signal 100 Ω ≤ RL ≤ 500 Ω
Switch-on current	Typ. 5.0 A/ 50 μs
Over voltage protection	≤ 36 V at all poles during power-up (60 s) ≤ 48 V to GND during the switch-on process (60 s)
Reverse polarity protection	≤ 36 V (at all poles) (ISO 16750-2)
Insulation resistance	Riso ≥ 10 MΩ, 60 s (ISO 16750-2)
Dielectric strength	500 V DC, 0 V against housing (ISO 16750-2)

Mechanical data

Scope of delivery	Accessories not included with delivery, please order seperately.
Dimensions	
	Construction size 48 mm (48f7 mm (for installation in a 48H8 bore hole))
	Ø pressure pipe 10 mm
	Ø O-ring 40.87 mm x 3.53 mm
	Ø support ring 42.6 mm x 48 mm x 1.4 mm
	M12 flange Construction DM 20x20 mm - hole pattern 14 mm (EN 61076-2-101)
	Length of stranded cable 80 mm
Material	
	Electronics enclosure Stainless steel 1.4305, AISI 303
	Pressure pipe Stainless steel 1.4404, AISI 316L
	O-ring NBR 70
	Support ring PTFE
	M12 plug insert Glass fiber reinforced polyamide, nickel-/gold-plated brass contacts
	M12 flange Nickel-plated brass with O-ring (NBR)
	Stranded cable sheath PVC/TPE

Ambient data

EMC	EU Directive 2014/30 / EU CE marking EU Directive 2009/64/EU Agricultural machinery
Generic standards	According to EN 61000-6-2 and EN 61000-6-3
Agricultural and forestry machinery	ISO 14982 EN13307/ ISO 13766

¹⁾ Taking into account self-heating, generated through constant electrical operation with supply voltage.

²⁾ Caused by the permitted temperature range of the O-ring seal, the hydraulic oil and the temperature-dependent signal quality of the position magnet.

³⁾ Relative humidity 55 %.

⁴⁾ Caused by dry storage of the O-ring in uninstalled state (no coating with oil).

Construction machinery	
Transient pulses	ISO 7637-2
ESD (air and contact discharge)	EN 61000-4-2 ISO/TR 10605
Enclosure rating	
Housing	IP67 (EN 60529)
M12 male connector	IP69k (ISO 20653)
Temperature	
Operating temperature range (electronics)	-40 °C ... +105 °C ¹⁾
Ambient temperature (fluid)	-30 °C ... +95 °C ²⁾
Storage temperature range	-20 °C ... +65 °C ^{3) 4)}
Permissible relative humidity	90 % (Condensation not permitted)
Resistance to shocks	Fall test in acc. with IEC 60068-2-31 100 g, 11 ms (Single shock in acc. with IEC 60068-2-27) 50 g, 11 ms (Continuous shocks, 1,000 shocks per spatial axis in acc. with IEC 60068-2-27)
Resistance to vibration	20 g, 24 h / spatial axis, 55 ... 2.000 Hz (IEC 60068-2-6) 18 g (r.m.s), 36 h / spatial axis, 10 ... 2.000 Hz (IEC 60068-2-80) 20 g (r.m.s), 48 h / spatial axis, 10 ... 2.000 Hz (IEC 60068-2-64)
Nominal operating pressure (P_N)	400 bar
Max. overload pressure during operation (P_N x 1.2)	480 bar
Max. test pressure in cylinder (P_N x 1.5)	600 bar
Note	For details of applied tests and descriptive standards, please see document 8021473

¹⁾ Taking into account self-heating, generated through constant electrical operation with supply voltage.

²⁾ Caused by the permitted temperature range of the O-ring seal, the hydraulic oil and the temperature-dependent signal quality of the position magnet.

³⁾ Relative humidity 55 %.

⁴⁾ Caused by dry storage of the O-ring in uninstalled state (no coating with oil).

General notes

Note	Accessories not included with delivery, please order separately.
-------------	--

Classifications

ECl@ss 5.0	27270705
ECl@ss 5.1.4	27270705
ECl@ss 6.0	27270705
ECl@ss 6.2	27270705
ECl@ss 7.0	27270705
ECl@ss 8.0	27270705
ECl@ss 8.1	27270705
ECl@ss 9.0	27270705
ECl@ss 10.0	27270703
ECl@ss 11.0	27270703
ETIM 5.0	EC002544
ETIM 6.0	EC002544
ETIM 7.0	EC002544
UNSPSC 16.0901	41111613

Dimensional drawing (Dimensions in mm (inch))

MAX48

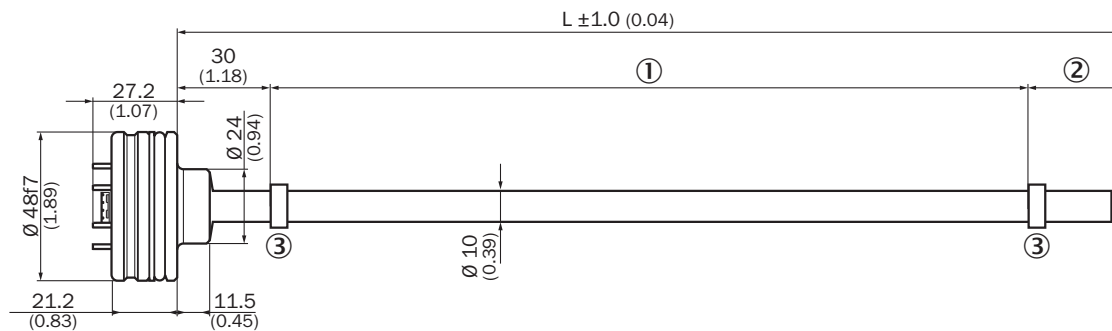

- ① Measuring range
- ② Damping zone
- ③ Position magnet

Male connector M12

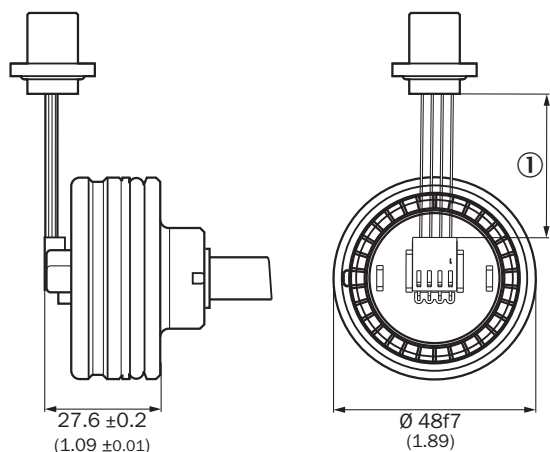

- ① Wire length (according to type code)

M12 connector type S/ flange - axial seal

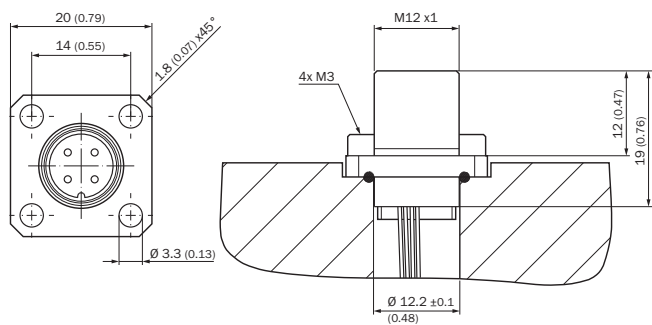

Installation of position magnet

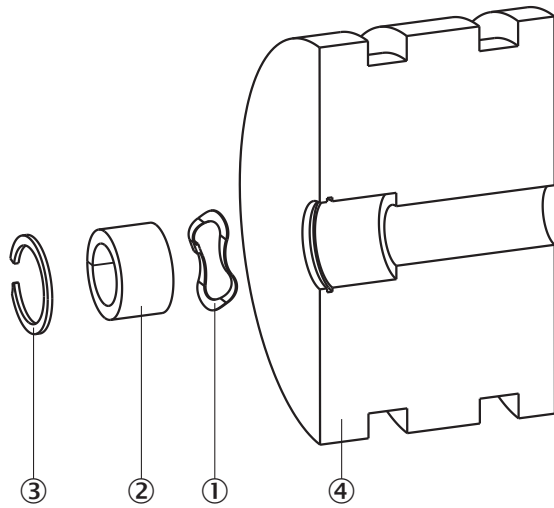

- ① Corrugated spring washer
- ② Position magnet
- ③ Circlip
- ④ Piston

Position magnet

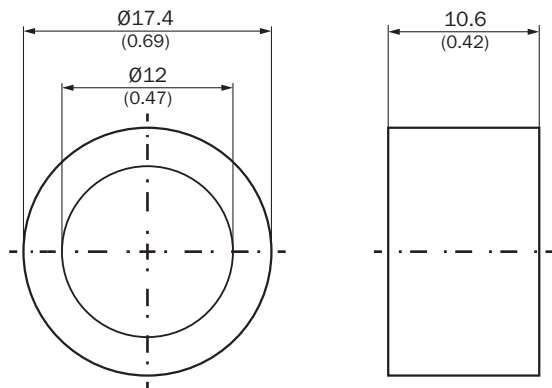

Circlip

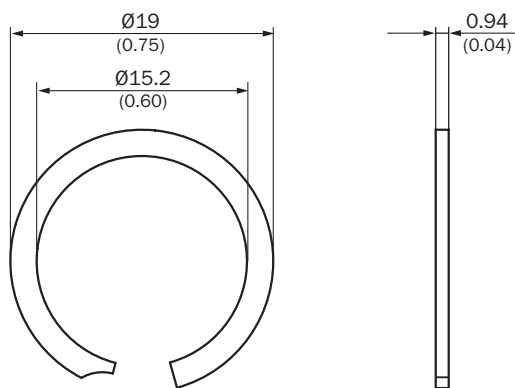

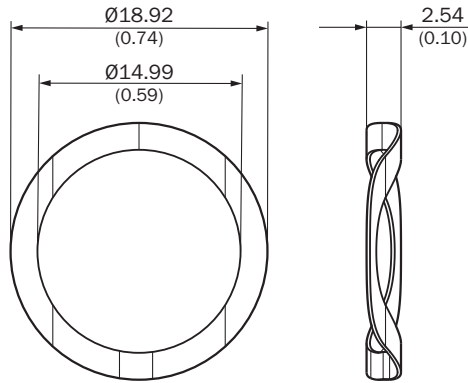

Corrugated spring washer



Recommended accessories

Other models and accessories → www.sick.com/MAX48

	Brief description	Type	Part no.
Other mounting accessories			
	1 piece, Retaining ring (Ø19 mm OD x Ø15.2 mm ID x 0.94 mm) for installing the position magnets in the piston of the hydraulic cylinder, Stainless steel 1.4319	BEF-MK-SR-01	2116437
	5 pieces, Retaining ring (Ø19 mm OD x Ø15.2 mm ID x 0.94 mm) for installing the position magnets in the piston of the hydraulic cylinder, Stainless steel 1.4319	BEF-MK-SR-05	2116438
	10 pieces, Retaining ring (Ø19 mm OD x Ø15.2 mm ID x 0.94 mm) for installing the position magnets in the piston of the hydraulic cylinder, Stainless steel 1.4319	BEF-MK-SR-10	2116439
	50 pieces, Retaining ring (Ø19 mm OD x Ø15.2 mm ID x 0.94 mm) for installing the position magnets in the piston of the hydraulic cylinder, Stainless steel 1.4319	BEF-MK-SR-50	2116440
	1 piece, Corrugated spring washer (Ø18.92 mm OD x Ø14.99 mm ID x 2.54 mm) for installing the position magnets in the piston of the hydraulic cylinder, 17-7 PH Condition CH900 stainless steel	BEF-MK-WF-01	2116431
	5 pieces, Corrugated spring washer (Ø18.92 mm OD x Ø14.99 mm ID x 2.54 mm) for installing the position magnets in the piston of the hydraulic cylinder, 17-7 PH Condition CH900 stainless steel	BEF-MK-WF-05	2116432
	10 pieces, Corrugated spring washer (Ø18.92 mm OD x Ø14.99 mm ID x 2.54 mm) for installing the position magnets in the piston of the hydraulic cylinder, 17-7 PH Condition CH900 stainless steel	BEF-MK-WF-10	2116433
	50 pieces, Corrugated spring washer (Ø18.92 mm OD x Ø14.99 mm ID x 2.54 mm) for installing the position magnets in the piston of the hydraulic cylinder, 17-7 PH Condition CH900 stainless steel	BEF-MK-WF-50	2116435
Magnets			
	Position magnet for magnorestrictive linear encoder, Ø 17.4 mm, height 10.6 mm	MAG-O-174-01	2112714
		MAG-O-174-05	2112713
		MAG-O-174-10	2115045
		MAG-O-174-50	2112711

SICK AT A GLANCE

SICK is one of the leading manufacturers of intelligent sensors and sensor solutions for industrial applications. A unique range of products and services creates the perfect basis for controlling processes securely and efficiently, protecting individuals from accidents and preventing damage to the environment.

We have extensive experience in a wide range of industries and understand their processes and requirements. With intelligent sensors, we can deliver exactly what our customers need. In application centers in Europe, Asia and North America, system solutions are tested and optimized in accordance with customer specifications. All this makes us a reliable supplier and development partner.

Comprehensive services complete our offering: SICK LifeTime Services provide support throughout the machine life cycle and ensure safety and productivity.

For us, that is “Sensor Intelligence.”

WORLDWIDE PRESENCE:

Contacts and other locations –www.sick.com